

**Technical data**

Displacement	4,9 l
Number of cylinders	4 in line
Cylinder head	Cross–flow
Valves/cyl	2 inlet and 2 exhaust
Aspiration	Turbocharged, air to water intercooled
Rotation facing flywheel	Anticlockwise
Injection system	Bosch Common Rail
Engine management	SisuTronic EEM3 with Bosch EDC7
Fulfills IMO, EC and RVIR marine engine exhaust emission standards	

**Engine Performance According to ISO 14396**

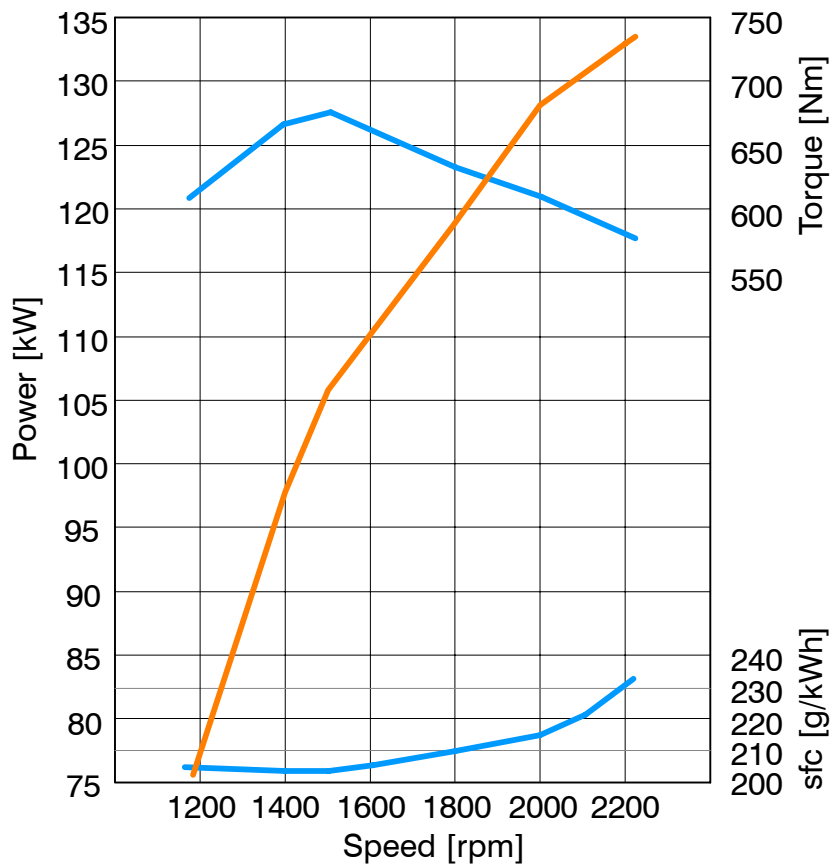

**Standard Equipment**

- Flywheel with SAE 3 housing
- 2–pole 12V electrical system, 65A alternator
- Freshwater–cooled exhaust manifold
- Integrated heat exchanger
- Seawater–cooled intercooler
- Gear–driven seawater pump
- Single–stage oil–wetted air cleaner
- Complete instrument panel and engine wiring harness

**Optional Equipment**

- Flywheel with SAE 1 or SAE 2 housing
- 2–pole 24V electrical system, 60A alternator
- Keel cooling system
- Expansion tank
- Block heater, 230V or 120V system
- Exhaust elbow, dry or wet
- Closed crankcase ventilation system
- Air filter and rain cap
- Engine brackets and rubber mountings
- Oil drain pump



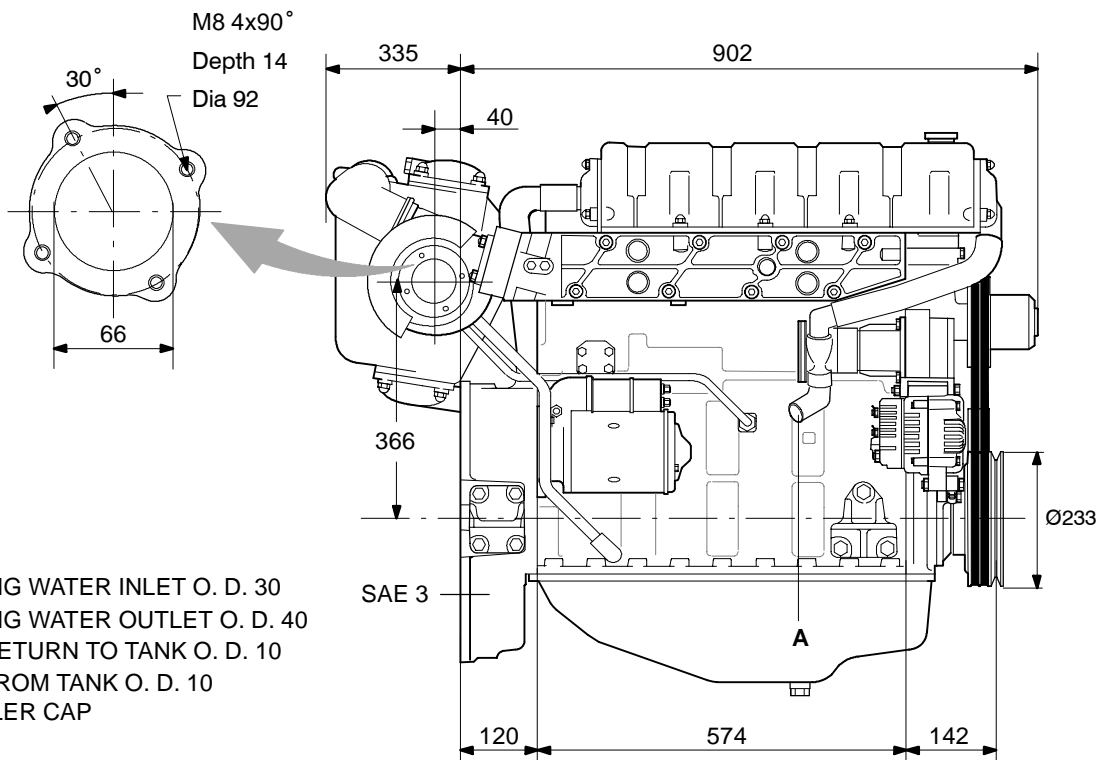
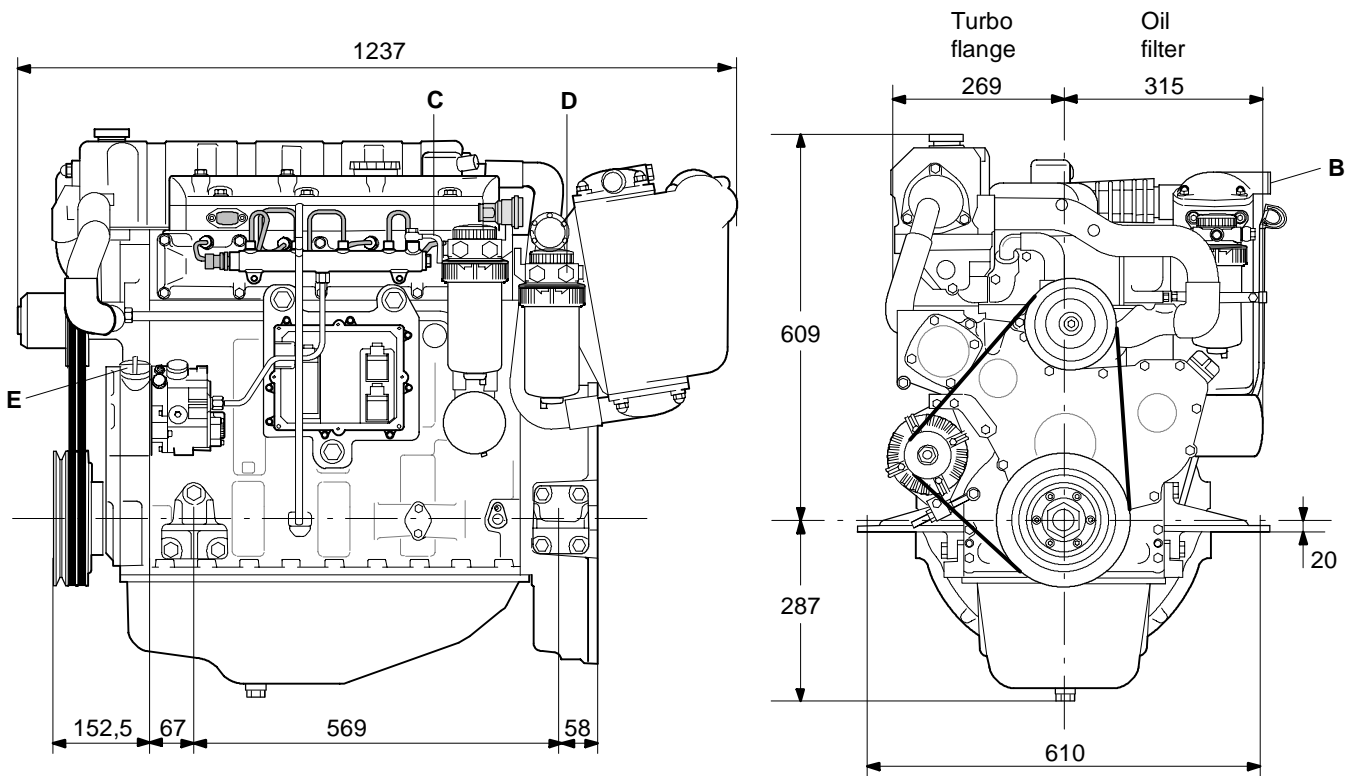

- A COOLING WATER INLET O. D. 30
- B COOLING WATER OUTLET O. D. 40
- C FUEL RETURN TO TANK O. D. 10
- D FUEL FROM TANK O. D. 10
- E OIL FILLER CAP

**Sisu Diesel Inc.**  
 Nokia, Finland  
 Tel +358 3 3417 111  
 Fax+358 3 3417 333  
 www.sisudiesel.com

